

PRODUCT

**TOOL TURRET**

MODEL

**BTP-80.3-8P**

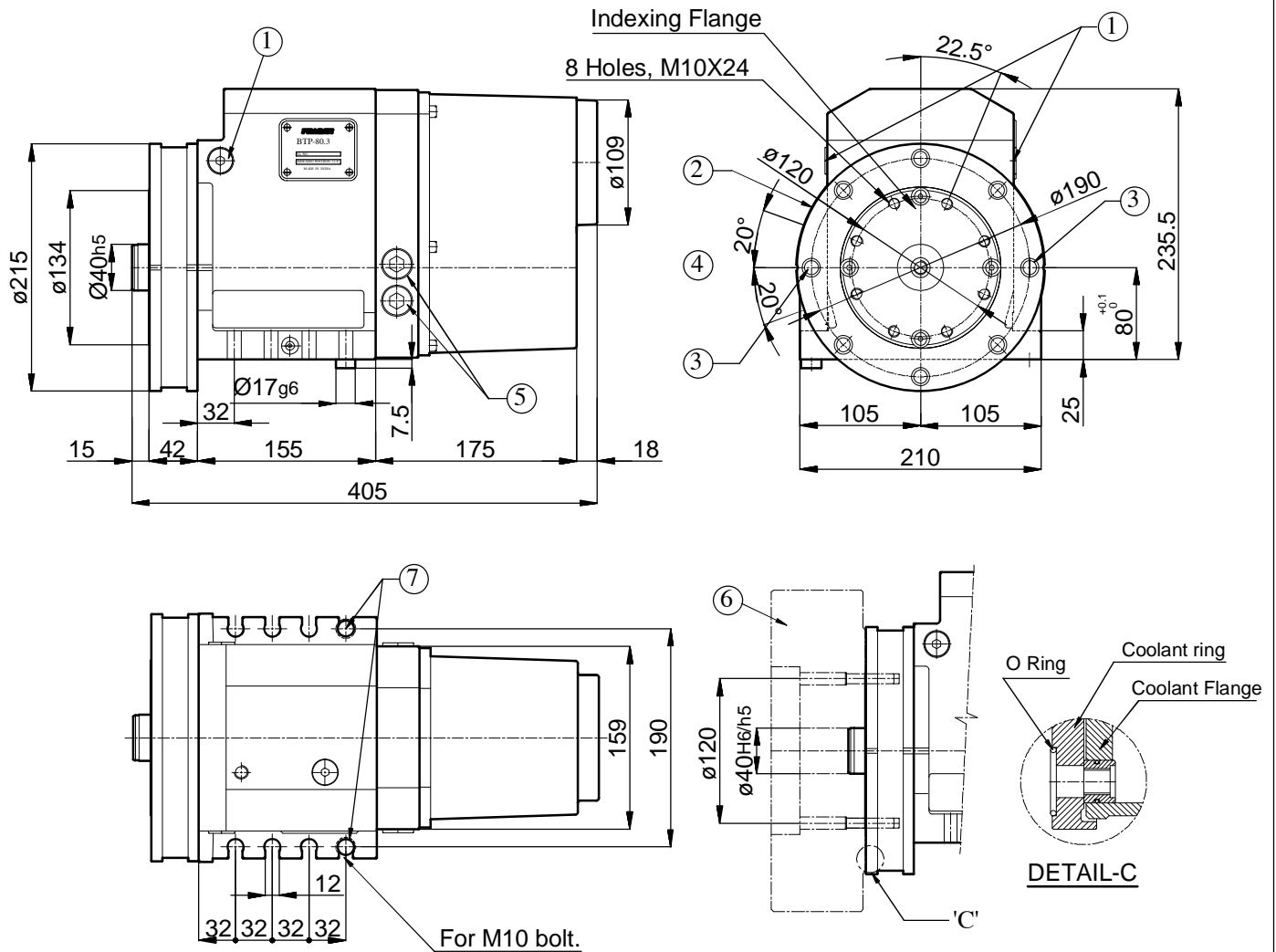

1. Coolant inlet from either side, BSP Thread size 3/8",
2. Coolant flange can be clamped to indexing flange at a suitable angular position depending on the indexing positions,
3. Alternate positions of coolant outlet valve,
4. Adjustment range of coolant outlet valve,
5. Electrical Connection 1/2" BSP,
6. Tool Disc,
7. Turret alignment pin.

**Technical Specification.**

Inertia of transportable masses		kgm <sup>2</sup>	1.00
Indexing time for 8 station.	45°	s	0.45
	90°	s	0.80
	180°	s	1.60
Indexing time for 12 station.	30°	s	0.45
	90°	s	1.15
	180°	s	2.30
Indexing frequency.		min <sup>-1</sup>	8
Repeat positioning accuracy.		s	±2
Indexing accuracy.		s	±6
Total weight without Tool disc.		kg	58

**Loading details.**

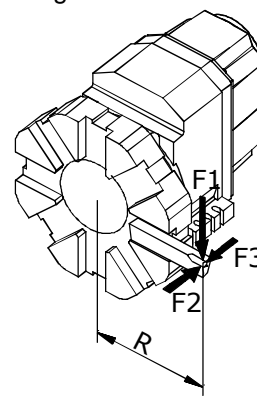

F1 x R	1500 Nm
F2 x R	1500 Nm
F3 x R	600 Nm

Scale

1:6

Projection

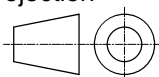

**PRAGATI AUTOMATION PVT. LTD.**

BANGALORE

Date

10.12.15

Drawing No.

**DB24**